



### Features

- Tight main static breakdown voltage tolerance ( $\pm 10\%$  - TA & TB series)
- Adjustable main static breakdown voltage (TG221 to TG226)
- Rugged ceramic-metal construction
- Refractory metal electrodes
- Corrosion-resistant stainless steel external surfaces (TB series)

### Applications

- High current surge generators
- Exploding bridge wire systems
- Crowbars
- Flashlamp triggers

### Standard Voltages

Series/ Part Number	Main Static Breakdown Voltage (Nom)	Unit
TA	1.0	kV
	2.0	kV
	5.0	kV
	7.0	kV
	10.0	kV
	15.0	kV
TB	2.5	kV
	5.0	kV
	10.0	kV
	15.0	kV
	20.0	kV
	25.0	kV
TG221	1.0-20.0	kV
TG222	18.0-40.0	kV
TG224	1.0-20.0	kV
TG225	18.0-40.0	kV
TG226	35.0-60.0	kV

Devices in the TA/TB/TG221-226 Series with other main static breakdown voltages in the 1.0-60.0kV range are available upon request.

### Description

High Energy Devices' Triggeregaps are high energy spark gaps that are capable of switching stored energy in a fraction of a microsecond upon command. Triggeregaps require no standby power, are extremely rugged, and require only a low-energy, high-voltage triggering pulse. The miniature TA series (1.0-15.0kV) provides switching capability for pulses with energy content as high as 50 joules. The larger TB series (2.5-25.0kV) will reliably switch pulses with up to 300 joules of energy. The TG221 to 226 (1.0-60.0kV) can switch pulses with energy contents of up to 6,000 joules and feature adjustable main static breakdown voltages.

### Ordering Information

A complete part number is represented by the digits below. Main static breakdown voltages are expressed in kV. For example, TA5.0 is a 5kV TA series device and TB25.0 is a 25kV TB series device.

Product Series / Part Number	Main Static Breakdown Voltage
TAX.X	1.0-9.0kV
TAXX.X	10.0-15.0kV
TBX.X	2.5-9.0kV
TGXX.X	10.0-25.0kV
TG221 to 226	As shown in the detailed specifications

## Specifications (@25°C)

Parameter	Conditions	Symbol	TA1.0			TA2.0			TA5.0			Units
			Min	Nom	Max	Min	Nom	Max	Min	Nom	Max	
<b>Device Specifications</b>												
Main Static Breakdown Voltage	100V/s	$E_z$	0.9	1.0	1.1	1.8	2.0	2.2	4.5	5.0	5.5	kV
Applied Voltage		$E_{bb}$	0.4	-	0.85	0.7	-	1.7	1.2	-	4.2	kV
Trigger Voltage <sup>(1)</sup>	$t_r=0.5\mu s$ , PW=3.0 $\mu s$	$e_{trig}$	3.0	-	2.5	3.0	-	2.5	3.5	-	2.5	kV pk
Dimension A		-	0.687	0.750	0.813	0.697	0.760	0.823	0.697	0.760	0.823	inches
<b>Life Ratings</b>												
Discharge Life <sup>(2)</sup>	5,000A Pulse Energy (as shown)	-	1,000	-	-	1,000	-	-	1,000	-	-	shots
Pulse Energy		-	45	-	-	50	-	-	50	-	-	J
Cumulative Charge <sup>(4)</sup>	Coulomb Rating	-	-	110	-	-	62	-	-	25	-	Q

## Specifications (@25°C)

Parameter	Conditions	Symbol	TA7.0			TA10.0			TA15.0			Units
			Min	Nom	Max	Min	Nom	Max	Min	Nom	Max	
<b>Device Specifications</b>												
Main Static Breakdown Voltage	100V/s	$E_z$	6.3	7.0	7.7	9.0	10.0	11.0	13.5	15.0	16.5	kV
Applied Voltage		$E_{bb}$	1.9	-	5.8	3.5	-	8.5	7.0	-	12.5	kV
Trigger Voltage <sup>(1)</sup>	$t_r=0.5\mu s$ , PW=3.0 $\mu s$	$e_{trig}$	3.7	-	2.8	5.0	-	3.5	8.0	-	4.5	kV pk
Dimension A		-	0.697	0.760	0.823	0.727	0.790	0.853	0.767	0.830	0.893	inches
<b>Life Ratings</b>												
Discharge Life <sup>(2)</sup>	5,000A Pulse Energy (as shown)	-	1,000	-	-	1,000	-	-	1,000	-	-	shots
Pulse Energy		-	50	-	-	60	-	-	70	-	-	J
Cumulative Charge <sup>(4)</sup>	Coulomb Rating	-	-	18	-	-	12	-	-	11	-	Q

## Specifications (@25°C)

Parameter	Conditions	Symbol	TB2.5			TB5.0			TB10.0			Units
			Min	Nom	Max	Min	Nom	Max	Min	Nom	Max	
<b>Device Specifications</b>												
Main Static Breakdown Voltage	100V/s	$E_z$	2.25	2.50	2.75	4.5	5.0	5.5	9.0	10.0	11.0	kV
Applied Voltage		$E_{bb}$	0.8	-	2.0	1.5	-	4.0	3.0	-	8.0	kV
Trigger Voltage <sup>(1)</sup>	$t_r=0.5\mu s$ , PW=3.0 $\mu s$	$e_{trig}$	3.1	-	1.8	3.2	-	1.9	4.6	-	2.1	kV pk
Dimension A		-	-	1.99	-	-	2.43	-	-	2.69	-	inches
Dimension B		-	-	-	0.23	-	-	0.23	-	-	0.58	inches
Dimension C		-	-	-	2.03	-	-	2.03	-	-	2.10	inches
<b>Life Ratings</b>												
Discharge Life <sup>(2)</sup>	5,000A Pulse Energy (as shown)	-	1,000	-	-	1,000	-	-	1,000	-	-	shots
Pulse Energy		-	150	-	-	150	-	-	300	-	-	J
Cumulative Charge <sup>(4)</sup>	Coulomb Rating	-	-	150	-	-	75	-	-	75	-	Q

### Specifications (@25°C)

Parameter	Conditions	Symbol	TB15.0			TB20.0			TB25.0			Units
			Min	Nom	Max	Min	Nom	Max	Min	Nom	Max	
<b>Device Specifications</b>												
Main Static Breakdown Voltage	100V/s	$E_z$	13.5	15.0	16.5	18.0	20.0	22.0	22.5	25.0	27.5	kV
Applied Voltage		$E_{bb}$	4.5	-	12.0	6.0	-	16.0	7.5	-	20.0	kV
Trigger Voltage <sup>(1)</sup>	$t_r=0.5\mu s$ , $PW=3.0\mu s$	$e_{trig}$	6.3	-	3.5	8.0	-	4.5	9.7	-	5.2	kV pk
Dimension A		-	-	2.69	-	-	2.81	-	-	2.79	-	inches
Dimension B		-	-	-	0.58	-	-	0.58	-	-	0.58	inches
Dimension C		-	-	-	2.10	-	-	2.10	-	-	2.10	inches
<b>Life Ratings</b>												
Discharge Life <sup>(2)</sup>	5,000A Pulse Energy (as shown)	-	1,000	-	-	1,000	-	-	1,000	-	-	shots
Pulse Energy		-	300	-	-	300	-	-	300	-	-	J
Cumulative Charge <sup>(4)</sup>	Coulomb Rating	-	-	50	-	-	38	-	-	30	-	Q

### Specifications (@25°C)

Parameter	Conditions	Symbol	TG221			TG222			TG224			Units
			Min	Nom	Max	Min	Nom	Max	Min	Nom	Max	
<b>Device Specifications</b>												
Main Static Breakdown Voltage	100V/s	$E_z$	1.0	-	20.0	18.0	-	40.0	1.0	-	20.0	kV
Applied Voltage		$E_{bb}$	0.5	-	18.0	15.0	-	35.0	0.5	-	19.0	kV
Dimension A		-	-	2.25	-	-	3.25	-	-	3.00	-	inches
Dimension B		-	-	-	6.0	-	-	7.0	-	-	7.0	inches
<b>Life Ratings</b>												
Peak Current	$PW=30\mu s$	-	20	-	-	20	-	-	50	-	-	kA
Discharge Life <sup>(3)</sup>	5,000A Pulse Energy (as shown)	-	1,000	-	-	1,000	-	-	1,000	-	-	shots
Pulse Energy		-	3,000	-	-	3,000	-	-	6,000	-	-	J
Cumulative Charge <sup>(4)</sup>	Coulomb Rating	-	-	375	-	-	188	-	-	750	-	Q

## Specifications (@25°C)

Parameter	Conditions	Symbol	TG225			TG226			Units
			Min	Nom	Max	Min	Nom	Max	
<b>Device Specifications</b>									
Main Static Breakdown Voltage	100V/s	$E_z$	18.0	-	40.0	35.0	-	60.0	kV
Applied Voltage		$E_{bb}$	15.0	-	35.0	30.0	-	55.0	kV
Dimension A		-	-	3.50	-	-	4.50	-	inches
Dimension B		-	-	-	8.0	-	-	9.0	inches
<b>Life Ratings</b>									
Peak Current	PW=30 $\mu$ s	-	50	-	-	50	-	-	kA
Discharge Life <sup>(3)</sup>	5,000A Pulse Energy (as shown)	-	1,000	-	-	1,000	-	-	shots
Pulse Energy		-	6,000	-	-	6,000	-	-	J
Cumulative Charge <sup>(4)</sup>	Coulomb Rating	-	-	375	-	-	166	-	Q

<sup>(1)</sup> The trigger voltages given in these tables are the minimum triggering voltages necessary for triggering at the corresponding applied voltage limits. As the applied voltage increases, the trigger voltage required for triggering decreases. It is assumed that the trigger is applied across the trigger and adjacent main electrodes — higher trigger voltages are required if it is applied across the trigger and opposite main electrodes.

<sup>(2)</sup> End point for life testing is a 20% reduction in the main static breakdown voltage.

<sup>(3)</sup> Because the main static breakdown voltage of these devices is adjustable, the trigger voltage required for any particular applied voltage cannot be specified. High Energy Devices suggests setting the main static breakdown voltage to at least 115% of the maximum applied voltage.

<sup>(4)</sup> The lifetime of the triggered gap can be approximated in terms of the cumulative charge, in coulombs (Q), that can be passed through the device without changing its main static breakdown voltage by more than 20 percent. Expressing the height of the current pulse in amperes and the duration in seconds, the area under the pulse is the coulomb of charge contained in it.

Example 1: A triggered gap is required to pass a 20,000 peak amp pulse having a 10 $\mu$ s pulse half-width.

Approximating the pulse shape by a triangle, the charge contained in the pulse is:

$$q = 20,000 \text{ amps} \times 10^{-5} \text{ sec} = 0.2 \text{ coulombs}$$

If the Coulomb Rating (Q) is given as 100 coulombs, the life under these conditions is approximately:

$$\text{Life} = Q/q = 100/0.2 = 500 \text{ discharges}$$

Example 2: A 10kV main static breakdown triggered gap must dump a 2.0 $\mu$ F capacitor charged to 8kV. The charge stored in the capacitor is:

$$q = CV = 2.0 \times 10^{-6} \text{ farads} \times 8,000 \text{ Volts}$$

$$q = 0.016 \text{ coulombs}$$

If the Coulomb Rating (Q) is given as 100 coulombs, the life under these conditions is approximately:

$$\text{Life} = Q/q = 100/0.016 = 6250 \text{ discharges}$$

**MECHANICAL DIMENSIONS**  
mm/(inches)

**TA Series**

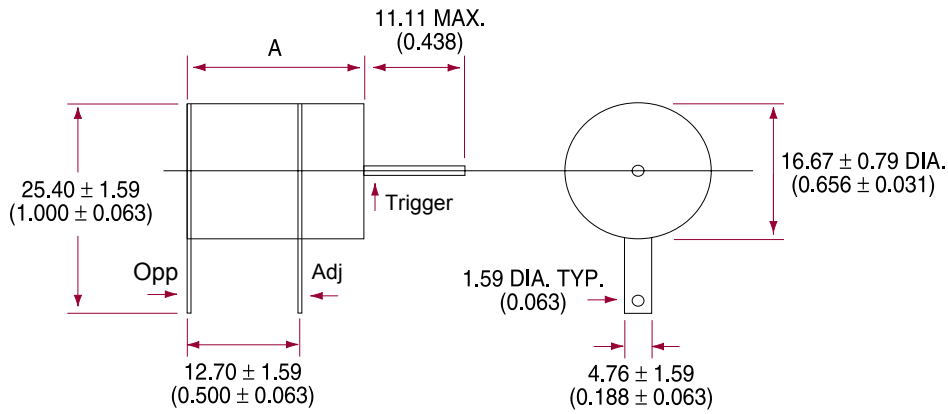

**TB Series**

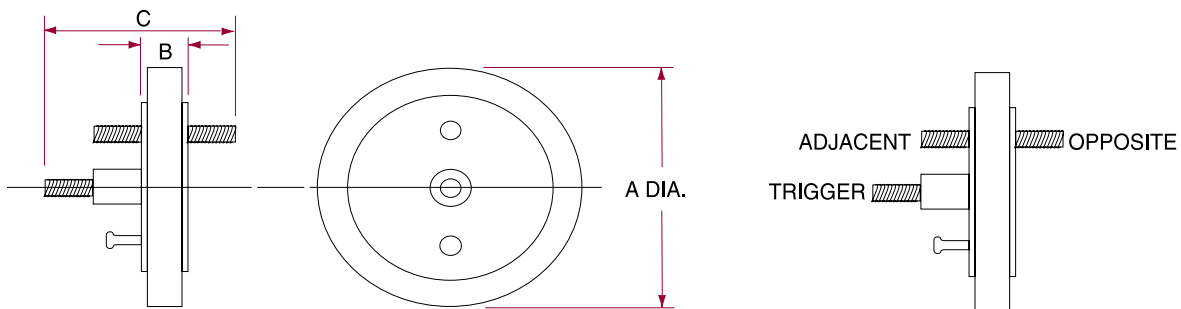

## Contact Information:

High Energy Devices, LLC  
26 Hollenberg Court  
Bridgeton, MO 63044  
Phone: 314.291.0030  
Fax: 314.291.8184  
E-mail: [info@highenergydevices.com](mailto:info@highenergydevices.com)  
[www.highenergydevices.com](http://www.highenergydevices.com)

---

HIGH ENERGY DEVICES, LLC MAKES NO REPRESENTATIONS OR WARRANTIES WITH RESPECT TO THE ACCURACY OR COMPLETENESS OF THE CONTENTS OF THIS PUBLICATION AND RESERVES THE RIGHT TO MAKE CHANGES TO SPECIFICATIONS AND PRODUCT DESCRIPTIONS AT ANY TIME WITHOUT NOTICE. NEITHER CIRCUIT PATENT LICENSES NOR INDEMNITY ARE EXPRESSED OR IMPLIED. EXCEPT AS SET FORTH IN HIGH ENERGY DEVICES' STANDARD TERMS AND CONDITIONS OF SALE, HIGH ENERGY DEVICES, LLC ASSUMES NO LIABILITY WHATSOEVER, AND DISCLAIMS ANY EXPRESS OR IMPLIED WARRANTY, RELATING TO ITS PRODUCTS INCLUDING, BUT NOT LIMITED TO, THE IMPLIED WARRANTY OF MERCHANTABILITY, FITNESS FOR A PARTICULAR PURPOSE, OR INFRINGEMENT OF ANY INTELLECTUAL PROPERTY RIGHT.

THE PRODUCTS DESCRIBED IN THIS DOCUMENT ARE NOT DESIGNED, INTENDED, AUTHORIZED OR WARRANTED FOR USE AS COMPONENTS IN SYSTEMS INTENDED FOR SURGICAL IMPLANT INTO THE BODY, OR IN OTHER APPLICATIONS INTENDED TO SUPPORT OR SUSTAIN LIFE, OR WHERE MALFUNCTION OF HIGH ENERGY DEVICES' PRODUCT MAY RESULT IN DIRECT PHYSICAL HARM, INJURY, OR DEATH TO A PERSON OR SEVERE PROPERTY OR ENVIRONMENTAL DAMAGE. HIGH ENERGY DEVICES, LLC RESERVES THE RIGHT TO DISCONTINUE OR MAKE CHANGES TO ITS PRODUCTS AT ANY TIME WITHOUT NOTICE.

---

Specification: TA/TB/TG221-226 Series  
©Copyright 2015, High Energy Devices, LLC  
All rights reserved. Printed in USA  
April 2015